

VRM KL RDM

HYDRAULIC CASING OSCILLATOR
HYDRAULIC CASING ROTATOR



VRM TYPE

HYDRAULIC CASING OSCILLATOR

GENERAL REMARKS

regarding hydraulic casing oscillator

The hydraulic casing oscillators have been designed in accordance with the latest technical know-how. Extremely sturdy construction guarantees worth-while use on site. By means of exact statical calculations in conjunction with higher quality material, an optimum conformity of loads, weight and material strength is archived. The internal welding stresses, not easily determined for the statical calculation, and which would affect the construction considerably, are eliminated by means of stress relieving prior to machining. A prominent feature of the equipment is the clamping collar consisting of five links operating on the boring implement. The individual links surround the casing like a chain so that a constant surface pressure is exerted on the casing circumference. In addition, the large height of the collar (400 and 700 mm. resp.) prevents any damage to the casings. By means of easily exchangeable reducer pieces the oscillator can be converted, within a few minutes, to a smaller casing diameter. The collar opens uniformly and enables unproblematic insertion of the casing with the cutting shoe. Another advantage of the machine is the low height on the excavator side. The excavator can be swivelled by 360° in the coupled condition. Attachment at the excavator itself is torque rigid and guarantees the transmission of the full rotating movement of 25° to the casing if the excavator is firmly situated.

The design and construction of the casing oscillator is based on the experience of many years of co-operation with companies specializing in pile foundations. In view of the high costs which would result from a breakdown of the equipment on site, great importance has knowingly been set on exceptionally sturdy construction.

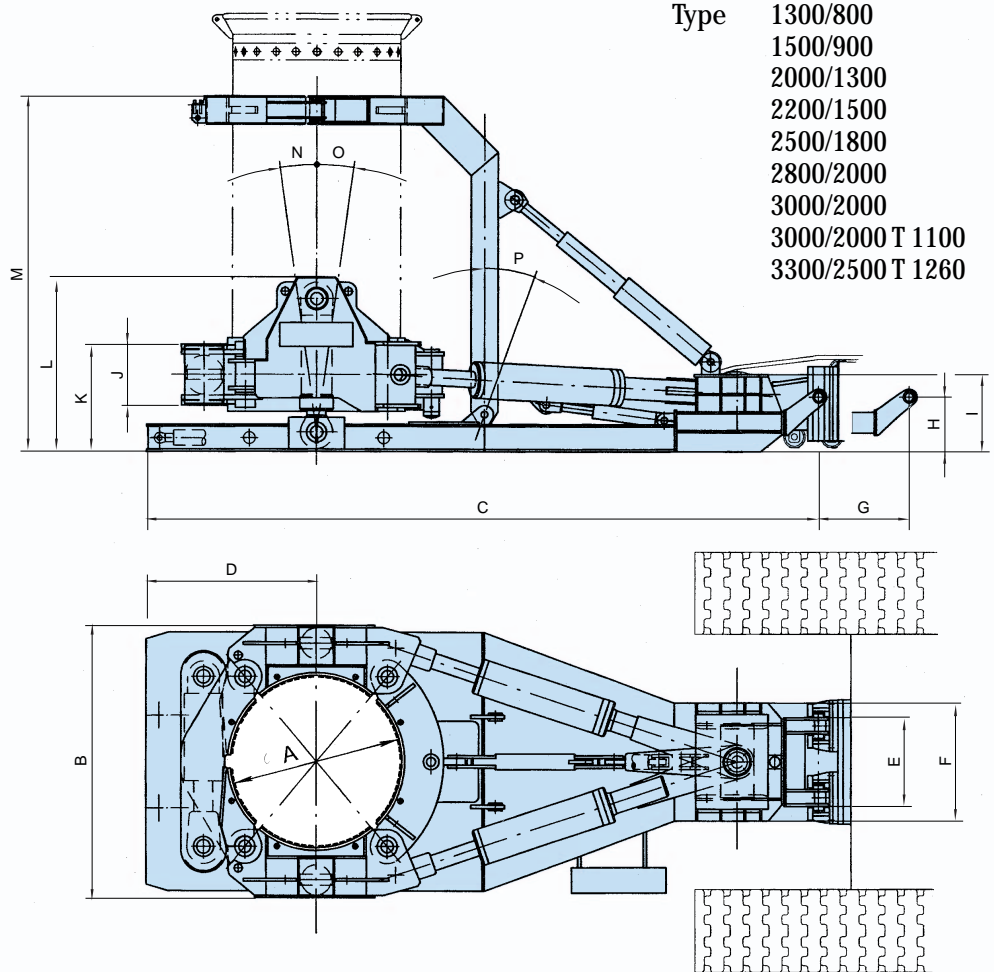

		VRM 1300	VRM 1500	VRM 2000	VRM 2200	VRM 2500	VRM 2800	VRM 3000	VRM 3000T 1100	VRM 3300T 1260
A	Max Casing diam.	mm	1300	1500	2000	2200	2500	2800	3000	3300
B	Width of machine	mm	2350	2850	3200	3400	4000	4300	4500	4880
C	Length of machine	mm	6500	6500	7500	7500	8800	9100	9140	10470
D	Min. spacing	mm	1200	1300	1600	1730	2230	2400	2600	2950
E	Width of cradle	mm	1015	1015	1015	1015	1015	1015	1015	1015
F	Width of machine excavator side	mm	1200	1400	1400	1400	1500	1500	1500	1600
G	Cradle path	mm	1300	1600	1300	1300	-	-	-	-
H	Axis excavator cradle	mm	700	700	700	700	700	700	700	700
I	Height of machine excavator side	mm	870	870	900	940	1130	1130	1165	1225
J	Height of cradle guide	mm	600	650	650	650	700	700	800	800
K	Height from ground to top of cradle guide	mm	1100	1200	1300	1300	1400	1400	1500	1620
L	Height of machine	mm	1800	1850	1950	2050	2580	2580	2610	2730
M	Height of casing guide	mm	2820	3220	3220	3220	-	-	-	-
N	Angle of inclination, in front	°	6°	6°	6°	6°	-	-	-	-
O	Angle of inclination, in rear	°	8°	8°	8°	8°	-	-	-	-
P	Angle of inclination (casing guide)	°	20°	20°	20°	20°	-	-	-	-

Stroke	mm	600	600	600	600	650	650	650	650	650
Lifting force	kN	1530	2050	2650	2650	5150	7250	7250	7250	9000
Clamping force	kN	1320	1660	2170	2170	3780	4780	4780	4780	5100
Rotation angle	°	25°	25°	25°	25°	25°	22°	21°	21°	24°
Torque	kNm	1660	2900	4110	4520	7070	8000	8350	11000	12620
Operating pressure	bar	270	270	270	270	300	300	300	300	300
Travel of casing	mm	284	327	436	480	546	538	550	550	690
Weight	t	12	17	25	27	40	48	52	54	63

ACCESSORIES

POWER PACK TYPE PP 616/300

for VRM 2500 + VRM 3000
RDM 1500 + RDM 2000

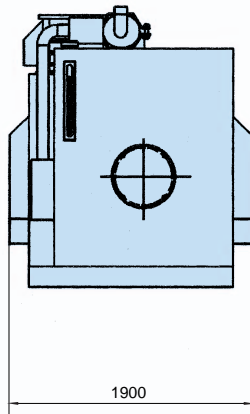
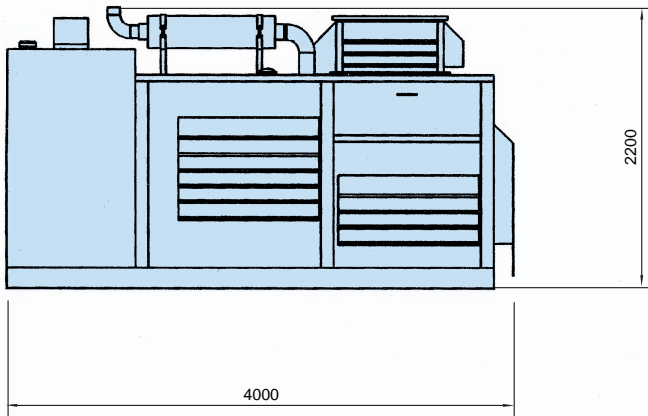

Motor		Deutz BF 6M 1015C
Power	kW (HP)	220 (300)
Revolutions	rpm	2000
Pumps Output	l/min	2 x 208 + 1 x 200
Operation pressure	bar	270 (max. 300)
Capacity Hydr. Oil/Fuel	l	2200 / 460
Dimensions LxWxH	mm	4000 x 1900 x 2200
Operation Weight	kg	6800
Specific Fuel Consumption	g/kW.h	189

POWER PACK TYPE PP 230/200

for VR 1500 + VRM 2000

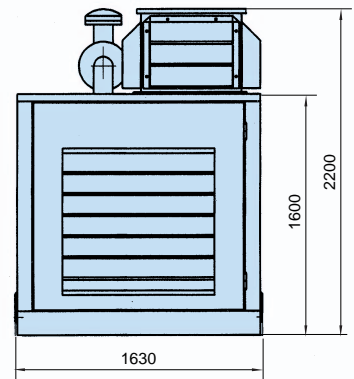
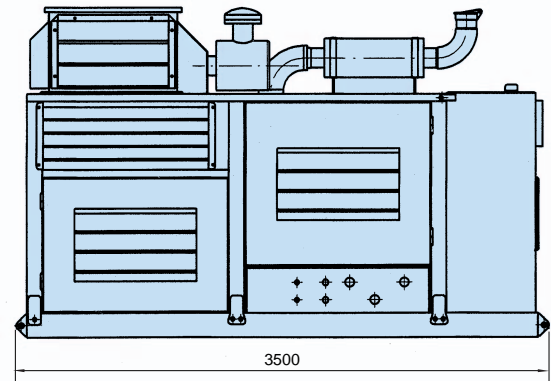

Motor		Caterpillar 3306 DI-II
Power	kW (HP)	169 (230)
Revolutions	rpm	2000
Pumps Output	l/min	2 x 200
Operation pressure	bar	270 (max. 300)
Capacity Hydr. Oil/Fuel	l	1300 / 400
Dimensions LxWxH	mm	3500 x 1630 x 2200
Operation Weight	kg	5500
Specific Fuel Consumption	g/kW.h	220

KL TYPE

HYDRAULIC CASING OSCILLATOR (COMPACT TYPE)

GENERAL REMARKS
regarding hydraulic
casing oscillators

The short hydraulic casing oscillators have been designed in accordance with the latest technical know-how. Extremely sturdy construction guarantees worth-while use on site. By means of exact statical calculations in conjunction with higher quality material, an optimum conformity of loads, weight and material strength is achieved. The internal welding stresses, not easily determined for the statical calculation, and which would affect the construction considerably, are eliminated by means of stress relieving prior to machining. A prominent feature of the equipment is the clamping collar consisting of five links operating on the boring implement. The individual links surround the casing like chain so that a constant surface pressure is exerted on the casing circumference. In addition, the large height of the collar (340-500 mm resp.) prevents any damage to the casings. By means of easily exchangeable reducer pieces the oscillator can be converted, within a few minutes, to a smaller casing diameter. The collar opens uniformly and enables onproblematic insertion of the casing with the cutting shoe. Attachment at the excavator itself is torque rigid and guarantees the transmission of the full rotating movement to the casing if the excavator is firmly situated.

The design and construction of the casing oscillator is based on the experience of many years of co-operation with companies specializing in pile foundation. In view of the high costs which would result from a breakdown of the equipment on site, great importance has knowingly been set on exceptionally sturdy construction.

Type VRM 100 KL
VRM 118 KL + 120 KL
130 KL
150 KL
200 KL

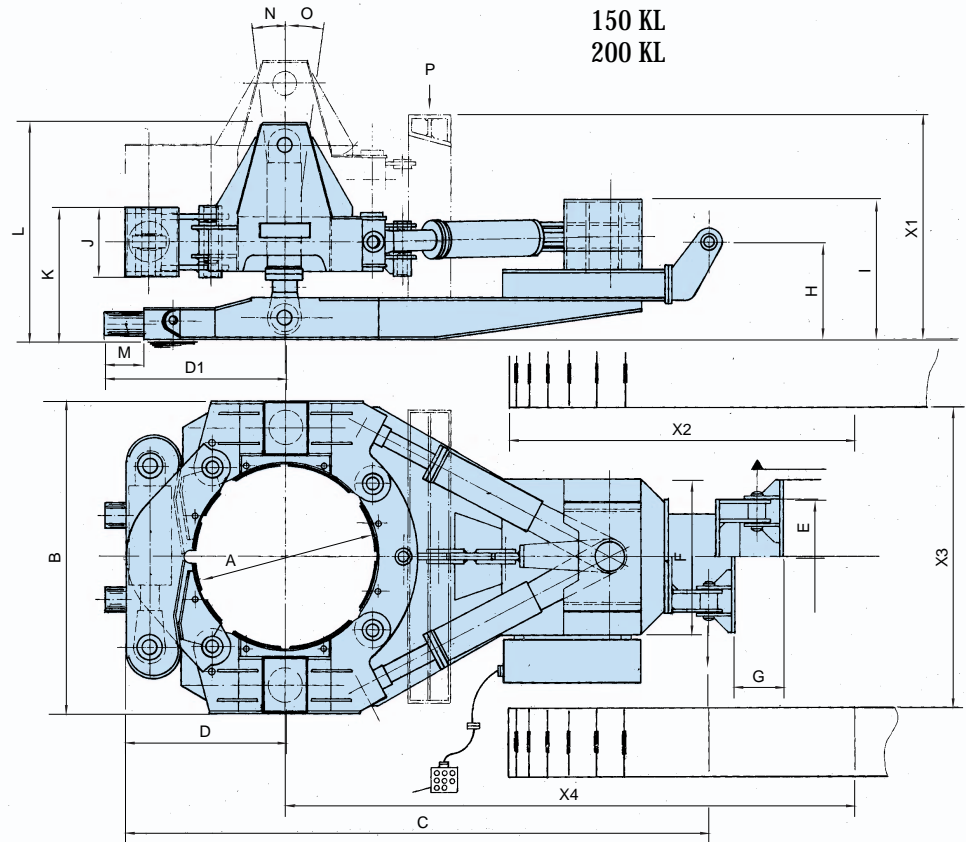

			VRM 100 KL	VRM 100+120 KL	VRM 130 KL	VRM 150 KL	VRM 200 KL
A	Max Casing diam.	mm	1000	1200	1300	1500	2000
B	Width of machine	mm	1850	2050	2250	250	3220
C	Length of machine	mm	2700	3270	3870	4070	4800
D	Min. spacing	mm	850	1000	1140	1270	1600
D1	W. retaining cycl.	mm	-	-	1455	1600	2000
E	Width of cradle	mm	565	800	800	800	800
F	Width of machine excavator side	mm	1050	1000	1100	1250	1400
G	Cradle path	mm	400	360	360	360	360
H	Axis excavator cradle	mm	630	630	630	630	630
I	Height of machine excavator side	mm	850	1000	1000	1100	1100
J	Height of cradle guide	mm	400	400	420	500	500
K	Height from ground to top of cradle guide	mm	850	810	1020	1020	1020
L	Height of machine	mm	1250	1485	1600	1600	1620
M	Retaining force	kN	-	-	440	600	800
N	Angle of inclination, in front		6°	6°	6°	6°	-
O	Angle of inclination, rear		8°	8°	8°	8°	-

Stroke	mm	320	400	450	450	450
Lifting force	kN	770	1000	1790	1790	1790
Clamping force	kN	500	1000	1560	1560	1560
Rotation angle		22°	22°	22°	22°	22°
Torque	kNm	630	1070	1700	1950	2430
Operating pressure	bar	p'=250 max 270	p'=250 max 270	p' max=315	p' max=315	p' max=315
Travel of casing	mm	190	250	250	285	350
Weight	t	4,8	7	10	11	14,5

ACCESSORIES

POWER PACK TYPE PP 90/62

for VRM 100 KL + VRM 120 KL
VRM 1000 L + VRM 1200 L

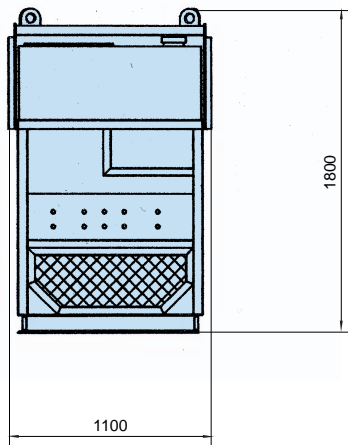
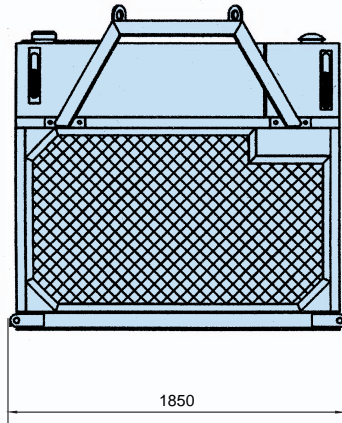

Motor		Hatz 4L 41C
Power	kW (HP)	45 (62)
Revolutions	rpm	2600
Pumps Output	l/min	2x90
Operation pressure	bar	270 (max. 300)
Capacity Hydr. Oil/Fuel	l	470 / 140
Dimensions LxWxH	mm	1850 x 1100 x 1800
Operation Weight	kg	2100
Specific Fuel Consumption	g/kW.h	210

RDM AND RDM/M TYPE

HYDRAULIC CASING ROTATOR

GENERAL REMARKS
regarding hydraulic
casing rotators

The hydraulic full 360 degree turning casing rotators are economically used to construct bored piles with the full casing method under hard soil conditions. The continuous cutting of the hard ground guarantees a boring speed satisfying to-day's requirements, even for compressive resistance of up to 2500 kg/cm².

The full 360 degree continuous turning of the casing minimizes the frictions compared to the oscillating method allowing the casing to drill down to 70 m depth with the casing rotator machines.

The first casing is fitted with carbide bits which can be adopted to the requirements of the soil conditions offering major advantages when coring through hard rock layers or when constructing secant pile walls.

The full 360 degree continuous turning of the casing by powerful hydraulic motors eliminates the possibility of pile mis alignment. Beyond that, the casing rotators are especially suitable for the construction of full casing displacement piles because of the ability to apply very high torque, push down and lifting forces on the casing which is not possible with the known drilling rigs.

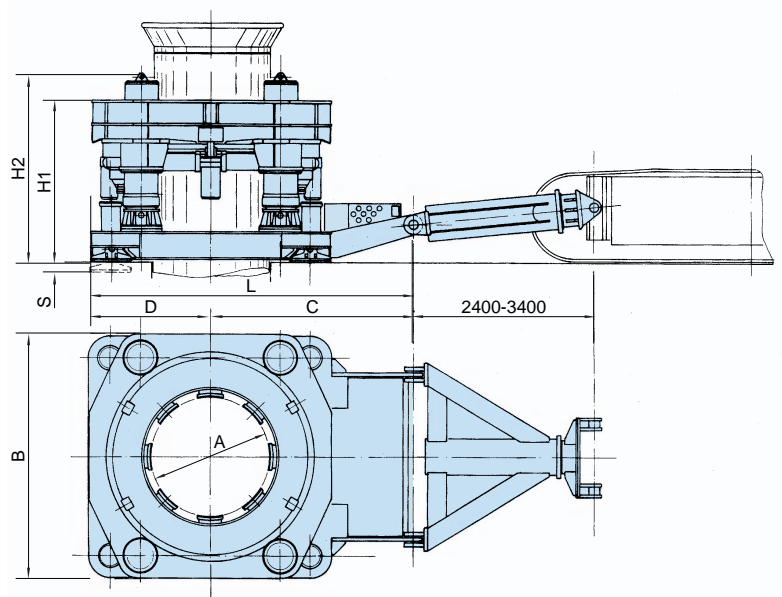
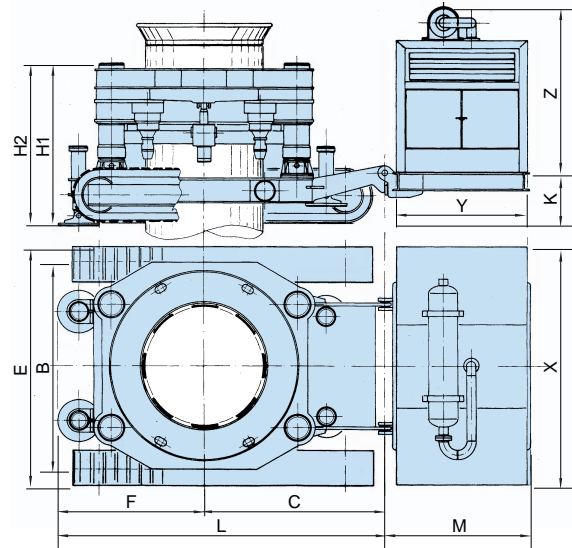

HYDRAULIC POWER PACK TECHNICAL DATA

Type	Power kW	Pump rating l/min	Dimensions mm	Weight kg
616/300 RDM 1500/RDM 2000	220-338-485	2x208-1x200	4000x2200x3000	7
1100/460 - RDM 2500	220-338-485	3x300-1x200	4000x2200x3000	12
1500/660 - RDM 3000	220-338-485	2x600-1x300	5500x2400x3000	20

			RDM 1500	RDM 2000	RDM 2500	RDM 3000
A	Max./min. casing diam.	mm	1500-800	2000-1200	2500-1500	3000-2000
LxB	Length x width	mm	4150x3100	6100x3500	6200x4300	6500x4600
C	-	mm	2600	3550	3000	3200
D	Min. spacing	mm	1550	2530	3000	3200
E	Width	mm	4000	4000	5300	5730
F	Min. spacing	mm	2200	2600	3000	3200
H1/H2	Height min./max.	mm	2050/2320	2600/2695	2600/2695	2600/2695
K	-	mm	800	900	900	900
M	-	mm	2000	2100	2600	2600
S	-	mm	150	350	450	450
	Lifting stroke	mm	600	600	600	600
	Lifting force	KN	1890	2400	3750	4560
	Rotation speed	rpm	0-1,1	0-1,0	0-1,1	0-0,09
	Torque	KNm	2300	2900	4700	7400
	Casing retaining force	KN	800	800	1200	1500
	Working pressure	bar	250 (max 300)	250 (max 300)	250 (max 300)	250 (max 300)
RDM			32	42	68	80
RDM-M	Weight	t	44	65	97	115

ACCESSORIES

POWER PACK TYPE PP 1100/460

for RDM-M 2500

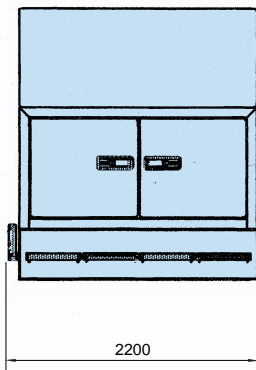
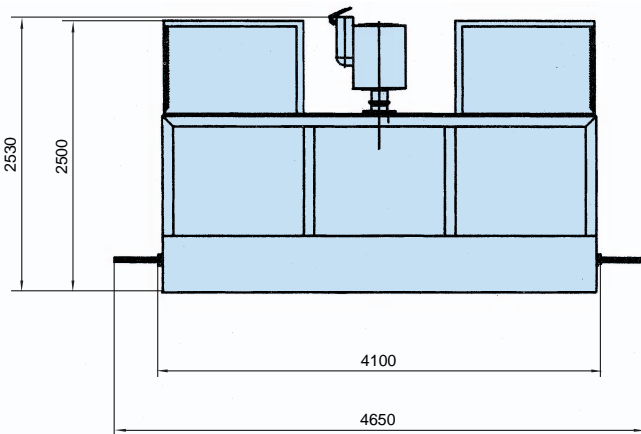

POWER PACK TYPE PP 1500/660

for RDM-M 3000/740

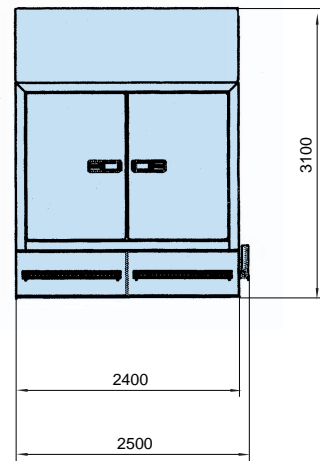
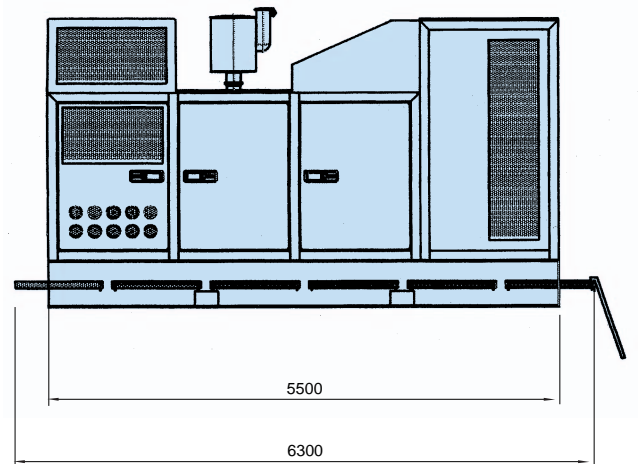

Motor		Caterpillar 3406 DI-TT
Power	kW (HP)	338 (400)
Revolutions	rpm	2000
Pumps Output	l/min	3x300 + 1x200
Operation pressure	bar	270 (max. 300)
Capacity Hydr. Oil/Fuel	l	1400 / 1400
Dimensions LxWxH	mm	4100 x 2200 x 2530
Operation Weight	kg	12000
Specific Fuel Consumption	g/kW.h	210

Motor		Caterpillar 3412 DI-TT
Power	kW (HP)	485 (660)
Revolutions	rpm	2100
Pumps Output	l/min	2 x 600 + 1 x 300
Operation pressure	bar	270 (max. 300)
Capacity Hydr. Oil/Fuel	l	3000 / 3000
Dimensions LxWxH	mm	5500 x 2500 x 3100
Operation Weight	kg	20000
Specific Fuel Consumption	g/kW.h	223

SOILMEC distributes machinery and structures all over the world, supported by SOILMEC subsidiary companies and representative offices as:

SOILMEC LTD - U.K.

SOILMEC MISR S.A.E. Co. - Egypt

SOILMEC (H.K.) Limited - Hong Kong

SOILMEC JAPAN CO LTD - Japan

SOILMEC S.P.A. - Beijing Repr. Office - P.R. China

SOILMEC FAR EAST PTE.LTD - Singapore

SOILMEC EMIRATES - U.A.E.

SOILMEC GULF - U.A.E.

CERTIFIED QUALITY SYSTEM

In 1990 Soilmec was awarded with the certification of its Quality System complying with ISO 9001:2000 standards.



SOILMEC S.p.A.

Drilling and Foundation Equipment

5819, via Dismano

47023 Cesena (FC) - Italy

tel. +39-0547-319111

fax +39-0547-318548

[http:// www.soilmec.it](http://www.soilmec.it)

e-mail: soilmec@soilmec.it



Stahl-und Apparatebau Hans Leffer Gmbh, Dudweiler, Pfählerstrasse 1, D-66125 Saarbrücken
Postfach 200360 • D-66044 Saarbrücken • Telefon 06897/793-0 • Telefax 06897/793330
e-mail: leffer-gmbh@t-online.de